

BEACon™

Ver. 2.0

BEACon™ are registered trademarks

All rights reserved. No part of this work covered by the copyright hereon may be reproduced or copied in any form or by any means - graphics, electronic, or mechanical, including photocopying, recording, taping, or information and retrieval systems - without written permission

Any software furnished under a license may be used or copied only in accordance with the terms of such license.

Note: Third-party brands and names are the property of their respective owners.

About the BEACon™

BEACon™ is a single door controller with built-in LCD and keypad. Connected to Reader, BEACon will eliminate the need for a host PC and enhance the security level of your application. With its easy operation, BEACon provides the best solution for a small office requiring simple access control system in a cost-effective manner.

About This Guide

This is an introduction to the installation of BEACon™. This guide describes how to install, examples for BEACon™ and technical specifications. The purpose of this guide is to provide instructions on using BEACon™ and troubleshooting minor problems.

Contents

About This Guide.....	4
Contents.....	5
Figures	7
1. Specifications	10
2. Installation guide.....	11
2.1. Board layout	11
2.2. Power Supply	11
2.3. Reader (fp-eGATE/BioEntry).....	12
2.4. Built-in RS232 to RS485 converter.....	12
2.5. Wiring guide.....	13
2.5.1. Power and earth ground connection	13
2.5.2. Fail-safe lock connection	14
2.5.3. Fail-secure lock connection	14
2.5.4. Reader connection	15
2.6. Installation examples.....	16
2.6.1. One door mode installation	16
2.6.2. Two door mode installation.....	17
3. Operation guide.....	18
3.1. Menu navigation.....	18
3.2. Default Display	18
3.3. Main Menu.....	19
3.4. User Management	20
3.4.1. Enroll User	21
3.4.2. Delete User.....	23
3.4.3. Delete All Users	26

3.5. System Setup menu	26
3.5.1. Operation Mode	26
3.5.2. Relay Configuration	27
3.5.3. Switch configuration	30
3.5.4. Lock-up password	33
3.5.5. Adjust time	34
3.5.6. IP Setting	34
3.5.7. ID Setting	35
3.5.8. Baudrate Setting	36
3.6. Attach Reader	36

Figures

Figure 1> BEACon board layout	11
Figure 2> Using the BEACon's built-in RS232 to RS485 converter	12
Figure 3> Connecting power and earth ground	13
Figure 4> Connecting Reader	15
Figure 5> Typical access control system using BEACon for one door mode	16
Figure 6> Typical access control system using BEACon for two doors mode	17
Figure 7> Main display	19
Figure 8> Main display - locked.....	19
Figure 9> Main menu	19
Figure 10> Lock-up confirmation	20
Figure 11> Password prompt	20
Figure 12> A password mismatch case	20
Figure 13> Choosing the reader to enroll a user.....	21
Figure 13> Checking reader status	21
Figure 14> Selecting the user ID to enroll.....	22
Figure 15> Enrolling as a duress finger	22
Figure 16> Enrollment process - placing finger to the reader	23
Figure 17> Choosing the reader to delete a user from	23
Figure 13> Checking reader status	24
Figure 18> Selecting user ID to enroll	24
Figure 19> Delete process - placing finger to the reader	26
Figure 20> Confirm to delete all the users... ..	26
Figure 25> BEACon Setup menu	26
Figure 26> System operation mode selection.....	26
Figure 27> Relay configuration in one door mode.....	27
Figure 28> Relay configuration in two door mode	27
Figure 29> Alarm configuration menu	28
Figure 30> The alarm output waveform	30
Figure 31> Alarm output configuration guide	30
Figure 32> Switch selection in one door mode	31
Figure 33> Switch selection in two door mode	31
Figure 34> Door status switch configuration.....	31
Figure 35> Switch function options for one door mode	32
Figure 36> Switch function options for two doors mode	32

Figure 37> Switch configuration parameters	33
Figure 38> Setting a new lock-up password.....	34
Figure 39> Entering current password	34
Figure 36> Setting current date.....	34
Figure 37> Setting current time	34
Figure 38> Setting IP address	34
Figure 39> Setting Netmask	35
Figure 40> Setting gateway address	35
Figure 41> Setting IP address	35
Figure 42> Setting BEACon ID	36
Figure 43> Setting Baudrate	36
Figure 44> Choosing the operation mode	37
Figure 45> Trying to detect the Reader connected to port 2	37
Figure 46> A reader is found with ID 234	37
Figure 47> Failed to detect or attach a reader	37

Revision History

Version	Date	Description
V1.0	2005.12.12	Created.
V2.0	2005.03.17	Changed enroll and delete operation. Added ID, IP and baudrate menu description. Changed Figure 4

1. Specifications

Operating temperature/humidity	-10 ~ 60°C, 0~90% RH, non-condensing
Supported doors	1 or 2, configurable
Supported readers	Up to 2 Reader
Relay output	4 x C type relays, configurable
Output relay ratings	5A / 250V AC
Switch input	6, configurable
Power requirements	1.5A @ 12V DC
Board dimension(mm)	130 x 150 x 25
Enclosure dimension(mm)	200 x 300 x 100
User Interface	16 x 2 character type liquid crystal display with numeric keypad
Communication	Built-in RS232 to RS485 converter for Reader network connectivity

2. Installation guide

2.1. Board layout

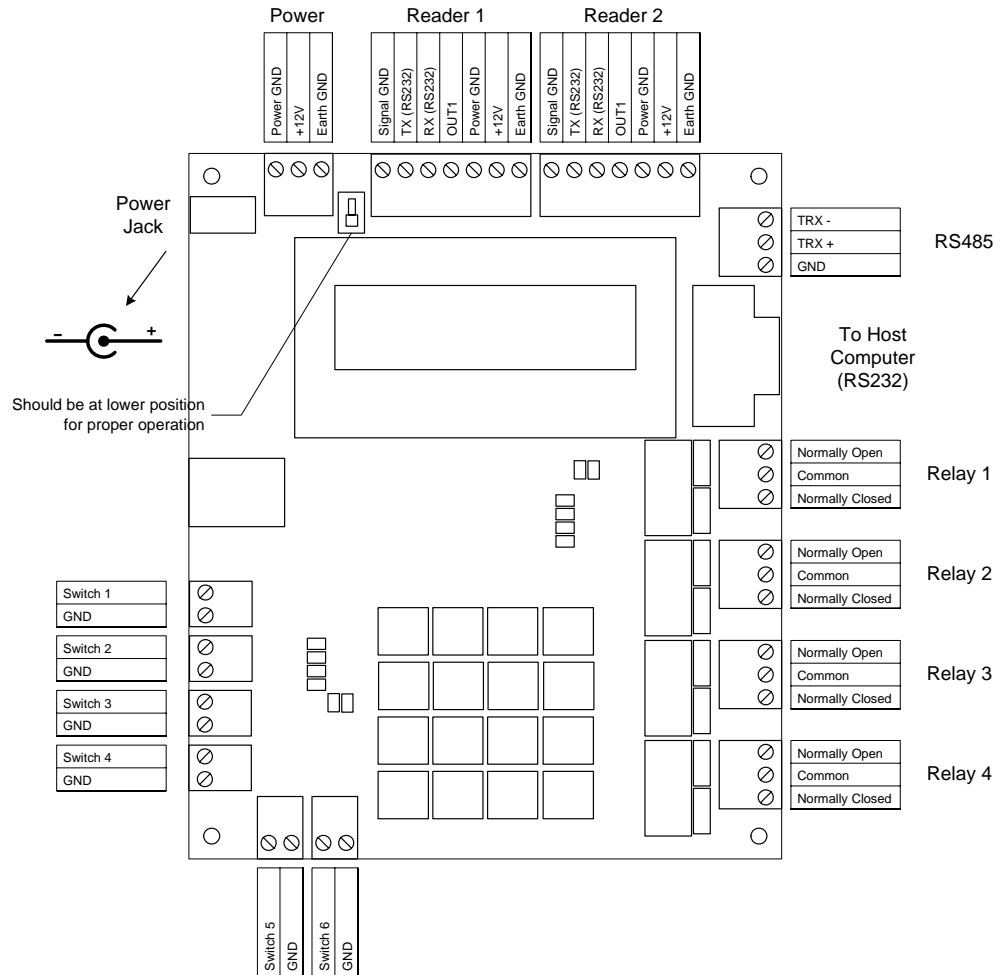

Figure 1> BEACon board layout

2.2. Power Supply

BEACon requires a DC power supply rated at 12V, 1.5A. The power supply unit is not included in the BEACon, but can be purchased separately.

The power can be supplied by a DC power jack or the terminal block, as shown in the Figure 1. Only one connection should be made, as the terminal block and the power jack are connected directly. No two power sources should be connected simultaneously.

2.3. Reader

BEACon can handle up to two Reader. By proper configuration, the reader(s) can be used with one or two doors.

2.4. Built-in RS232 to RS485 converter

BEACon provides RS232 to RS485 conversion for Reader network. By simply connecting to a standard RS232 port of a personal computer, the user can access the Reader network with BioAdmin software.

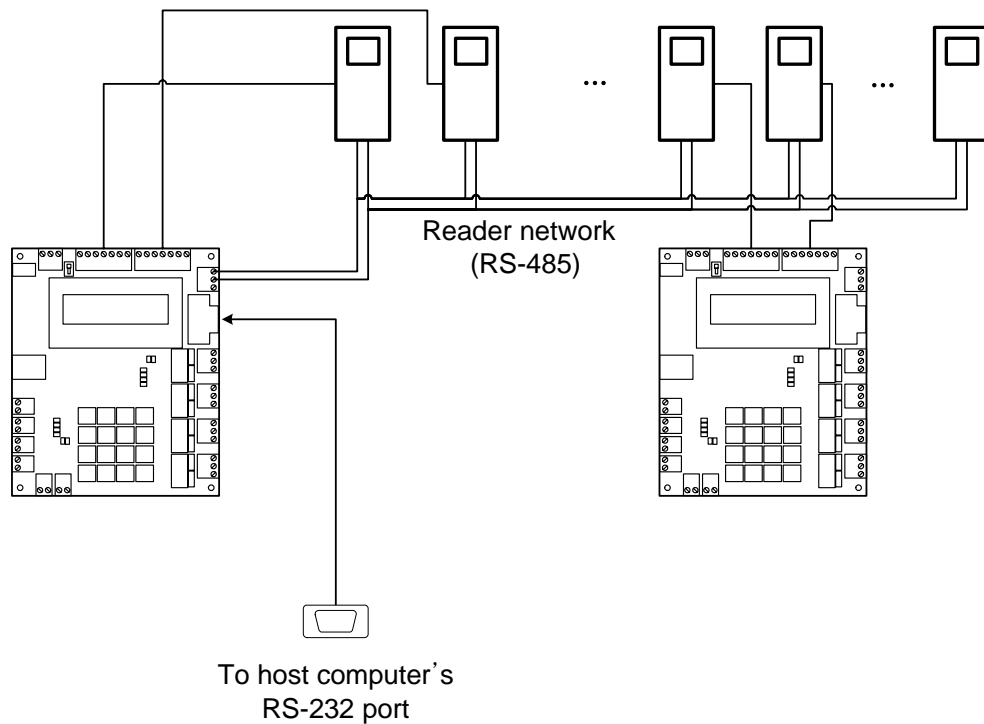

Figure 2> Using the BEACon's built-in RS232 to RS485 converter

2.5. Wiring guide

2.5.1. Power and earth ground connection

Use one method illustrated in the Figure 3 Only one method should be chosen exclusively.

Be sure to make proper connection for earth ground to minimize emission and optimum ESD tolerance of Reader.

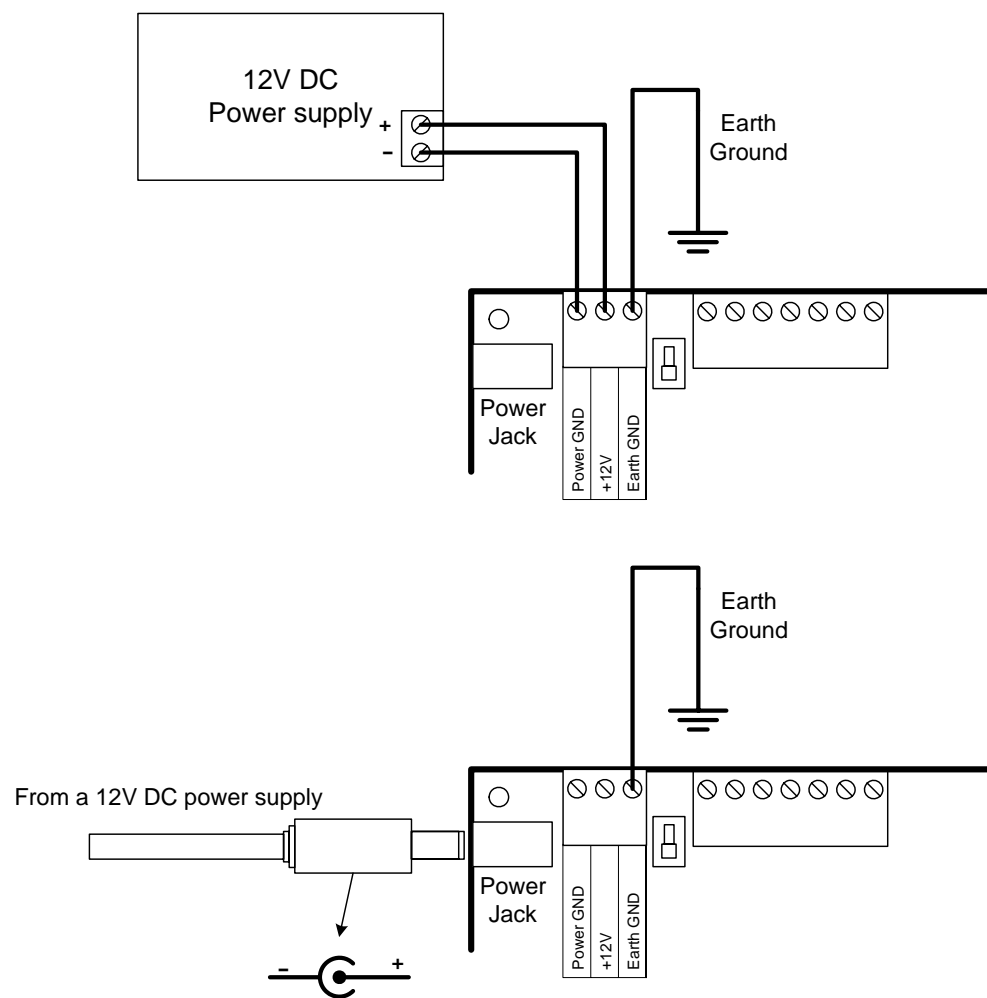
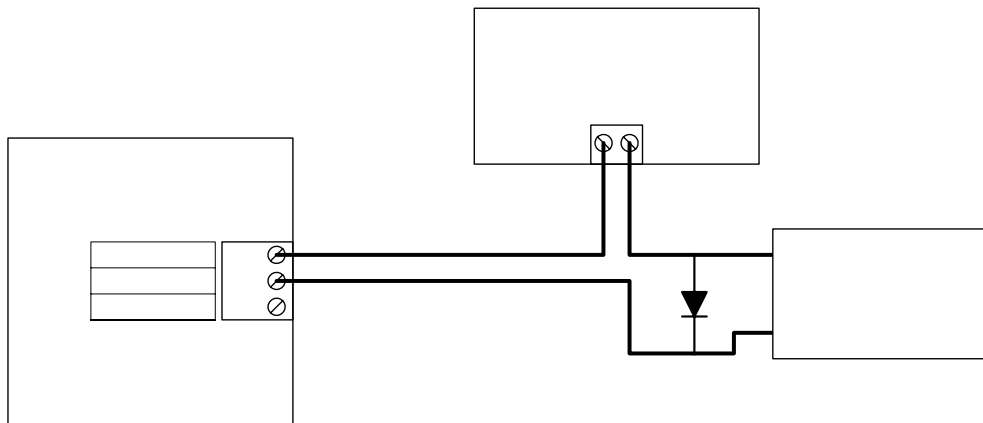
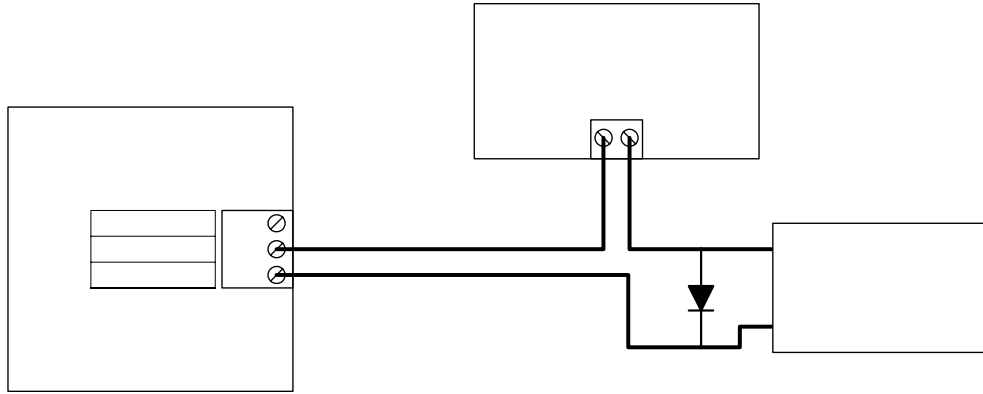

Figure 3> Connecting power and earth ground



2.6. Installation examples

2.6.1. One door mode installation

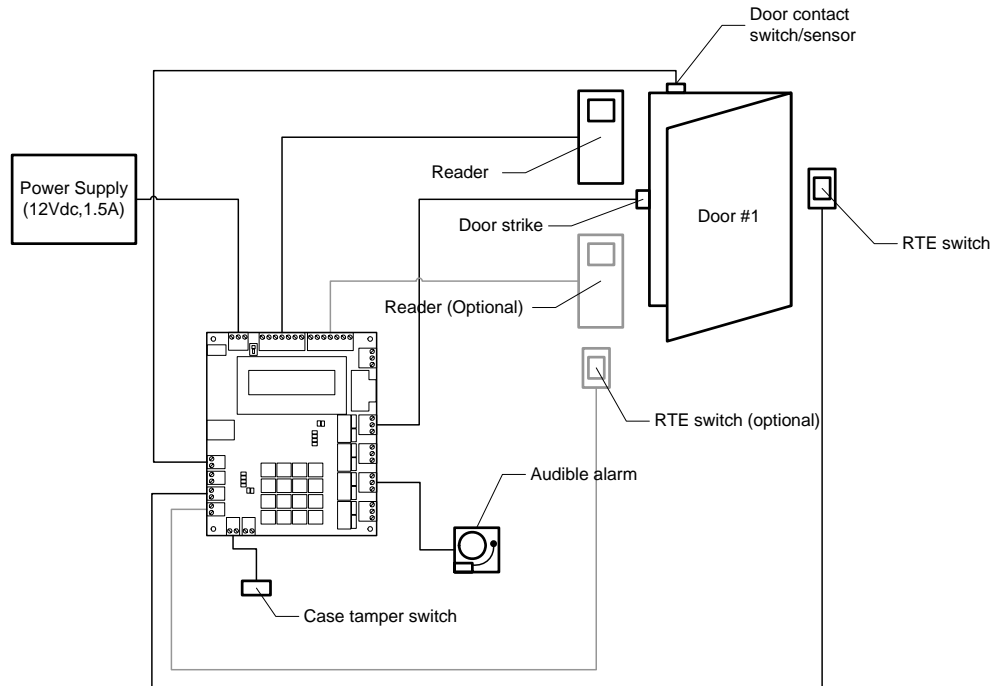

Figure 5> Typical access control system using BEACon for one door mode

2.6.2. Two door mode installation

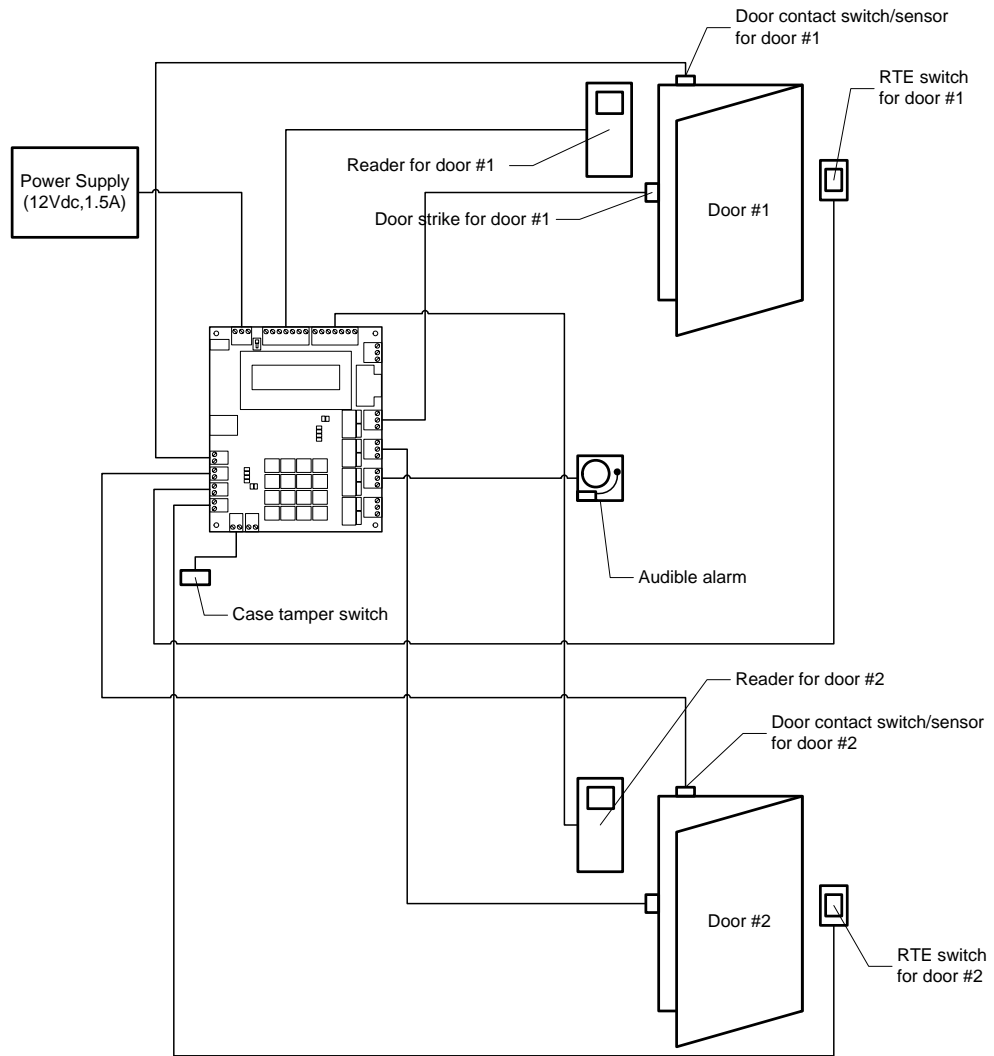

Figure 6> Typical access control system using BEACon for two doors mode

3. Operation guide

BEACon Access Controller provides a LCD display and numeric keypads for configuration and monitoring.

3.1. Menu navigation

BEACon provides an easy to use interface for configuration and installation purposes. Most functions are accessible through intuitive menu driven interface.

As the LCD is limited in its size, only partial image of a menu is displayed for menus longer than two rows. User should navigate with UP/DOWN keys to scroll up and down the current view. Please note that, in this manual, the whole menu list will be shown at once instead of splitting the views.

- Key definitions

MENU	Press this key to activate the menu.
ENT	For numeric input functions, this key is used to 'enter' typed numbers. For confirm stages, this key is used as a 'Yes' answer.
ESC	For menu navigation, this key is used to return to upper level menu. For numeric input functions, this key is used to delete the last typed number. For confirm stages, this key is used as a 'No' answer.
0-9	For menu navigation, these keys are used to select the same numbered menu item. For numeric input functions, these keys act as conventional numeric keys.
Up/Down Arrow	For menu navigation, these keys are used to scroll up and down for menus that are longer than the LCD height.

3.2. Default Display

- Display

The default display is illustrated in the Figure 7. If the menu is locked up, the padlock icon should appear locked as in the Figure 8. The lock-up should be applied to the menu system only. That is, the rest part of the BEACon should be completely functional.

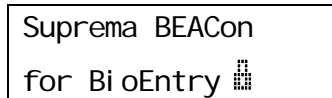

Figure 7> Main display

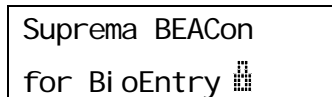

Figure 8> Main display - locked

3.3. Main Menu

- Menu Display

To invoke the menu system, press **Menu** button at the default display. The menu should appear as in the Figure 9

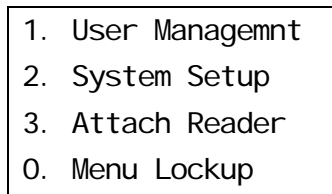
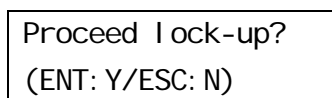
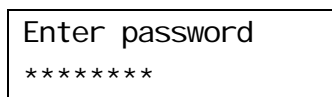

Figure 9> Main menu

- Locking the system up

Due to security reasons, you may want to lock up the menu system of the BEACon. To lock up the menu, you must configure the password first. See section 3.5.4 for password configuration menu. To practically lock up the system, press "0" on the main menu. Then following message will be showed on the LCD. After that, press the password which was selected previously according to the section 3. 5. 4.



After lock-up confirmation, the default display should look like as below.

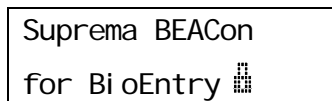

Figure 10> Lock-up confirmation

- Unlocking password protected system

For a locked-up BEACon, the system will prompt for the password as in the Figure 11 instead of displaying the menu. If the entered password matches with the registered one, the lock-up will be released temporarily, and the menu will be displayed. However, the system will be automatically locked-up again in 10 seconds after the last keystroke.

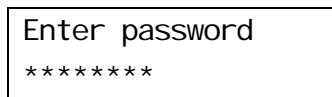

Figure 11> Password prompt

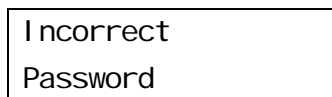
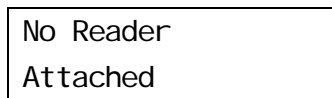

Figure 12> A password mismatch case



- Menu items

User Management	Enroll, delete and browse user list stored in the Reader
System Setup	Setup the BEACon – Configure the relay and switch behaviors, operation mode, and password for lock up.
Attach Reader	Attach Reader to the system.
Menu Lockup	Lock-up the BEACon menu for security – Select this menu item to lockup the menu instantly. This only applies if the password is configured previously.

3.4. User Management

Enroll, delete, browse user list stored in the Reader.

- Display

User Management
1. Enroll User
2. Delete User
3. Delete All

- Menu Items

Enroll User	Enroll a user to selected reader.
Delete User	Delete a user from selected reader
Delete All	Delete all users from selected reader

3.4.1. Enroll User

- Select reader to perform enrollment

The first step to enroll a user with BEACon is choosing the reader to perform the enrollment. This only applies when two readers are attached to the BEACon. If you have only one reader attached, this step will be skipped and the attached reader will be used during enrollment process.

Select Reader (1: #1, 2: #2)

Figure 13> Choosing the reader to enroll a user

- Check Reader Status

Once you select the reader to enroll, BEACon will check whether the selected reader is alive. If the reader is not alive, error message will be displayed as in Figure 14. After this error message, enroll phase will be finished.

If the reader is alive, next step will be continued.

Error Reader Status

Figure 14> Checking reader status

- Select User ID to enroll

Now that the reader is chosen, the next step is selecting the user ID(Figure 13).

Type an ID to enroll and press **ENT** button to proceed.

There are two methods to select an ID to enroll: manual ID selection and

automatic ID selection.

For manual ID selection method, choose an ID in a range between 1 and 4294967295($2^{32} - 1$). For automatic ID selection, choose 0 to let the Reader choose a lowest empty number .

Enter User ID
ID: 0 (0: Auto ID)

Figure 15> Selecting the user ID to enroll

- Enrolling as a duress finger

The readers provide means to enroll as duress finger. Please note that duress mode is only applicable in existing user ID. If you chose to select the ID automatically, this phase will be skipped.

As in the Figure 16, pressing **ENT** button will enable duress finger mode. Press **ES** **C** for normal enroll mode.

Enrl. as Duress?
(ENT: Y/ESC: N)

Figure 16> Enrolling as a duress finger

- Place the finger to be enrolled

Now that the reader and the user ID is chosen, you can place the finger to be enrolled to the reader.(Figure 17).You have to place or swipe the finger twice to enroll a finger.(See Figure 17, ① and ③)

If any error occurred during any phase of this process, the corresponding error message is displayed as in the Figure 17-⑦. In this figure, it is assumed that the placed finger was not adequate to be enrolled, so it is requesting the user to try the entire enroll process again.

When the placed finger is enrolled successfully, the display will show the enrolled user ID, as in the Figure 17-⑥.

- Copying the user data to the other reader

In a dual reader configuration, to enroll to both readers at once, you may want to copy this finger data to the other reader. So there is another option in dual reader mode. Before displaying enroll success message(Figure 17-⑥), a confirmation screen is displayed.(Figure 17-⑤). The destination reader will be different from

the enrolling reader chosen at the Figure 13.

On confirmation of copying process, the finger data of the same user ID in the target reader will be deleted before copying.

- End of enrollment

The last message, whether the enrollment was successful or not, will be displayed for 10 seconds, and the menu will be closed. If you press any key within 10 seconds however, the user ID selection menu will be displayed again, so you can continue to enroll other finger(s) consequently.

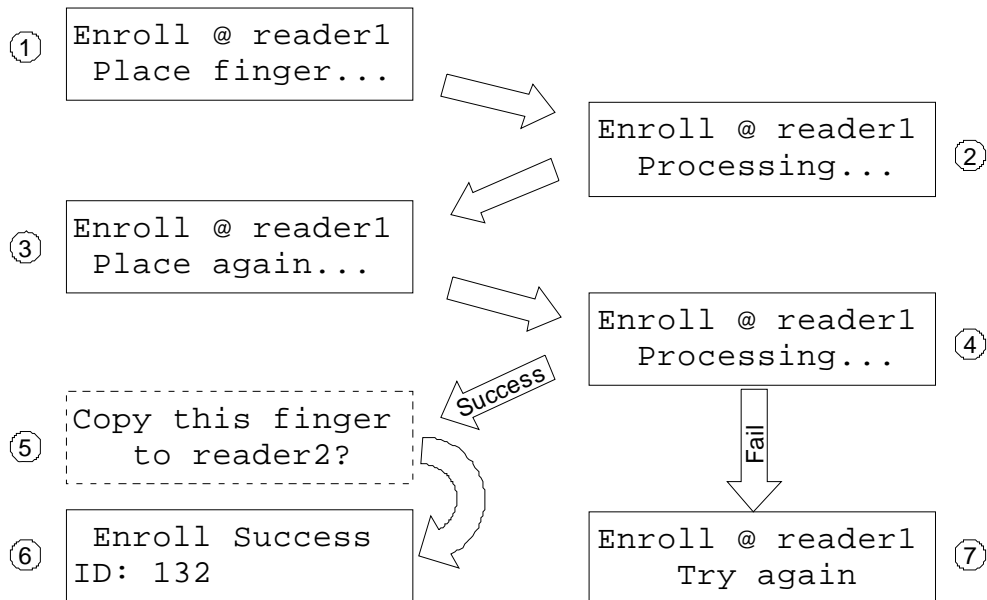

Figure 17> Enrollment process - placing finger to the reader

3.4.2. Delete User

- Select reader to delete a user from

The first step to delete a user with BEACon is choosing the Reader to delete from. This only applies if two readers are attached to the BEACon. If you have only one reader attached, this step will be skipped and the attached reader will be used during delete process.

```

Select Reader
(1: #1, 2: #2)
    
```

Figure 18> Choosing the reader to delete a user from

- Check Reader Status

Once you select the reader to delete user, BEACon will check whether the selected reader is alive. If the reader is not alive, error message will be displayed as in Figure 19. After this error message, enroll phase will be finished.

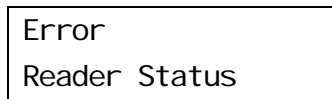

Figure 19> Checking reader status

- Select User ID to delete

Now that the reader is chosen, the next step is selecting the user ID to delete. Type the user ID to delete and press **ENT** button to proceed.

There are two methods to select the ID to delete: manual ID selection and identification with the finger.

If you know the user ID to delete, type the user ID, which is the same with the number you used in enrollment.

For finger identification method, choose 0. You have to place the finger to be deleted from the Reader, and the reader will search its user database for matching ID. See next section for details.

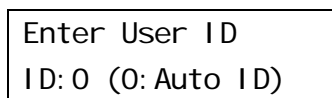

Figure 20> Selecting user ID to enroll

- Place the finger to be deleted

If the finger identification method is selected, the Reader waits for a finger to delete. You can place the finger to delete from the reader.(Figure 21).

If the placed finger is not found in the user database, the delete process will be canceled as shown in the Figure 21-⑥.

- Delete confirmation

After ID selection phase, you must confirm for deletion for selected or identified user ID.(Figure 21-④)

As the deletion is irrevocable process, care should be taken while proceeding this

phase. You can proceed to delete the user by pressing **ENT** key, or cancel further process by pressing **ESC**.(Figure 21-⑤)

- Delete the same user from the other reader

In a dual reader configuration, you may want to delete finger data from the other reader, to delete from both readers at once. So there is another option in dual reader mode. Before displaying delete success message(Figure 21-⑧ or ⑨), a confirmation screen is displayed.(Figure 21-⑦). The target reader will be different from the enrolling reader chosen at the Figure 18. If you press **ENT** key, the same ID will be deleted from the other reader. You may skip this phase by pressing **ESC** key, to leave the other reader unaffected.

- End of deletion

The last message will be displayed up to 10 seconds, and the menu will be closed. If you press any key within 10 seconds however, the user ID selection menu will be displayed again, so you can continue to delete other finger(s) consequently.

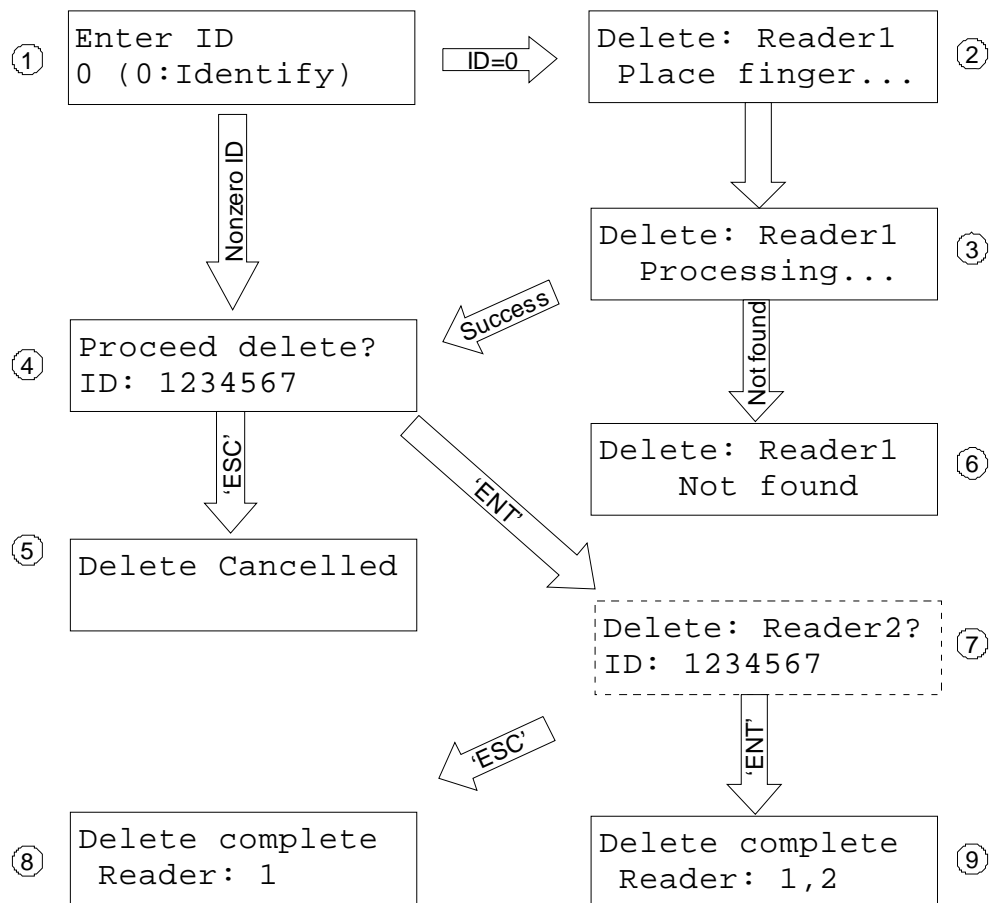

Figure 21> Delete process - placing finger to the reader

3.4.3. Delete All Users

This menu will delete all user entries of the selected reader.

After selection of the target reader, a confirmation screen should appear as in the Figure 22. To prevent unintended deletion, the confirmation key in this menu is **9**.

Please note that this process is irrevocable. You should be careful before confirming the deletion.

Delete All?(9: Y) 1220 user(s)

Figure 22> Confirm to delete all the users...

3.5. System Setup menu

Configures the BEACon access controller and adjusts date and time for attached readers

1. Op. Mode 2. Relay Config. 3. Switch Config. 4. Lock-up Passwd 5. Adjust Time 6. IP Config 7. ID Setting
--

Figure 23> BEACon Setup menu

3.5.1. Operation Mode

BEACon operates in one door mode or two door mode. Choose the right mode for your installation.

Operation Mode 1. One door mode 2. Two doors mode

Figure 24> System operation mode selection

The I/O configuration differ for each configurations, shown as in the Table 1.

I/O ports	I/O Functions	
	One door mode	Two door mode
Relay 1	Door #1 Unlock	
Relay 2	Alarm #3	Door #2 Unlock
Relay 3	Alarm #1	
Relay 4	Alarm #1	
Switch 1	Door #1 Status	
Switch 2	Configurable	Door #2 Status
Switch 3	Door #1 RTE	
Switch 4	Configurable	Door #2 RTE
Switch 5	Configurable	
Switch 6	Configurable	

Table 1> Input/Output definitions according to operation modes

3.5.2. Relay Configuration

Relay Config.
1. R#1: D#1 Unlock
2. R#2: Alarm #3
3. R#3: Alarm #1
4. R#4: Alarm #2

Figure 25> Relay configuration in one door mode

Relay Config.
1. R#1: D#1 Unlock
2. R#2: D#2 Unlock
3. R#3: Alarm #1
4. R#4: Alarm #2

Figure 26> Relay configuration in two door mode

- Relay output configuration - Door unlock

The door unlock output is activated on the following conditions:

Reader authentication	The user is verified or identified successfully by the reader. Note that a duress finger is authenticated as well as normal fingers.
RTE input	The RTE switch is activated for selected door.

In one door mode, both readers are mapped to the door #1, so the door is

unlocked by any of the reader's authentication.

In two door mode, the door #1 and the door #2 are unlocked on active RTE #1 and RTE #2, respectively.

For door unlock relays, there is only one parameter to configure, as shown in the Table 2.

Configuration Item	Description
Duration	Door unlock duration in milliseconds. The maximum duration is 60000 ms, which is 60 seconds.

Table 2> Configuration parameter for door unlock output

- Relay output configuration - Alarm

As the alarm output can be activated by multiple events, the alarm waveform can be configured differently for different events.

Alarm Config.
1. Alarm On Ev.
2. Alarm Off Ev.
9. Save Changes
0. Clear Config.

Figure 27> Alarm configuration menu

Alarm On events	One or more events that activate this alarm output. See Table 4 for available events.
Alarm Off events	One or more events that explicitly deactivate this alarm output. If any of the alarm off events is triggered, the alarm will be deactivated, regardless of remaining duration or pulse counts. See Table 4 for available events.
Save Changes	Save current configuration for this alarm output.
Clear Config	Clears all event configurations for this alarm output.

Table 3> Alarm configuration menu items

For selected alarm on events, the following events can be chosen.

Event	Description
Reader events	

Granted by reader #1/#2	A user verification is successful, and the access is granted by the reader
Denied by reader #1/#2	A user verification is unsuccessful, so the access is denied by the reader
Duress finger in reader #1/#2	A user verification is successful, but the finger was a duress finger
Tamper detect in reader #1/#2	A tamper attempt is detected by the reader
Door events	
Door #1/#2 forced open	The door is detected to be open, without RTE input nor successful reader authentication
Door #1/#2 held open	The door is held open for too long period of time
Other event	
Tamper #1 ~ #3	Tamper detected. The BEACon can handle up to three different tamper inputs. You must configure a switch as corresponding tamper input.

Table 4> Events used in alarm outputs

For each selected alarm on events, the following parameters need to be configured.

Alarm waveform parameters	
High	Minimum high of the alarm in milliseconds, in the range from 1 to 60000 ms. Set 0 to activate indefinitely. The alarm should be deactivated after this period of time, while the cause of the alarm is removed.
Low	The alarm output can be set as periodic pulse, if the low is set nonzero. The low must be greater than the high. Set 0 for non periodic output.
Count	For periodic outputs, you can restrict the number of output pulse in the range of 1 to 255. Set 0 for infinite numbers of pulse outputs.

Table 5> Configuration parameters for alarm output

For alarm outputs, you can configure the output high as infinite, by setting as 0. Once the alarm is activated, it will not self-deactivate unless an alarm off event occurs. See Figure 28 and Figure 29 for waveform configuration concepts.

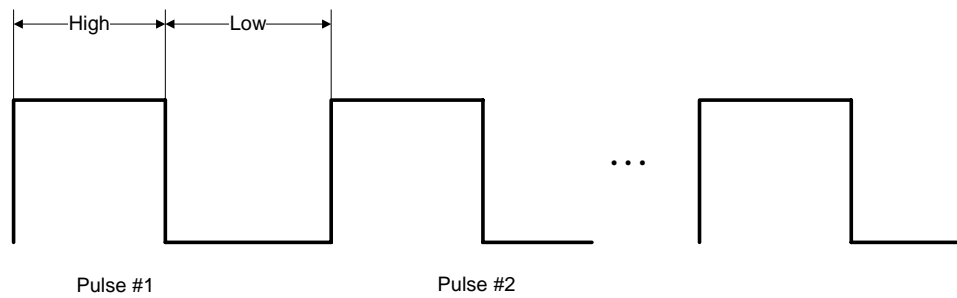

Figure 28> The alarm output waveform

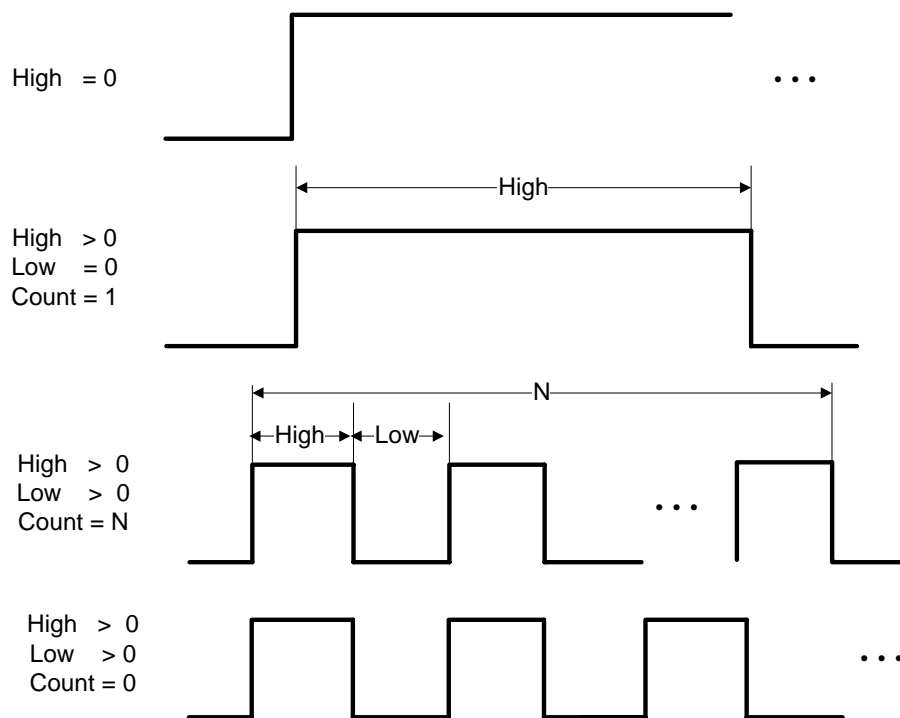

Figure 29> Alarm output configuration guide

3.5.3. Switch configuration

The switches for door status and RTE inputs are fixed as shown in the Figure 30 and Figure 31. The remaining switches can be configured separately and mapped to certain functions in relay configuration menu.

In one door mode, the switch #1 and #3 are fixed as the door status input and RTE for the door #1 respectively.

In two door mode, the switch #1 and #2 are fixed as door status for the door #1 and #2, and the switch #3 and #4 are fixed as RTE for the door #1 and #2 respectively.

Swi tch Confi g.
1. S#1: D#1 Status
2. Swi tch #2
3. S#3: D#1 RTE
4. Swi tch #4
5. Swi tch #5
6. Swi tch #6

Figure 30> Switch selection in one door mode

Swi tch Confi g.
1. S#1: D#1 Status
2. S#2: D#2 Status
3. S#3: D#1 RTE
4. S#4: D#2 RTE
5. Swi tch #5
6. Swi tch #6

Figure 31> Switch selection in two door mode

Specific configuration menu differs slightly according to the switch functions.

- Switch configuration for Door status

Lock Del ay
0 (ms)

Swi tch Type
1(1: N. C. /2: N. O.)

Hel d open del ay
0 (ms, 0: di sabl e)

Save?
(ENT: Y/ESC: N)

Figure 32> Door status switch configuration

Item	Description
Lock Delay	Delay before the door strike locks again, to wait for the door to be mechanically stabilized in closed position
Switch type	The polarity of the switch. Choose polarity from Normally Open (N.O.) or Normally Closed (N.C.)
Held open delay	Delay before the held open alarm activates when the door is held open for excessive period of time. If door is closed, held open alarm deactivates.

Switch configuration for RTE and configurable input

<p>Switch Function</p> <ol style="list-style-type: none"> 1. RTE #1 2. Tamper #1 3. Tamper #2 4. Tamper #3 5. CLR Alarm #1 6. CLR Alarm #2 7. CLR Alarm #3

Figure 33> Switch function options for one door mode

<p>Switch Function</p> <ol style="list-style-type: none"> 1. RTE #1 2. RTE #2 3. Tamper #1 4. Tamper #2 5. CLR Alarm #1 6. CLR Alarm #2 0. Disable Switch
--

Figure 34> Switch function options for two doors mode

Specific configuration menu differs slightly according to the switch functions.

- Switch configuration for Door status

<p>Delay</p> <p>0 (ms)</p>

Switch Type
2(1: N. C. /2: N. O.)

Save?
(ENT: Y/ESC: N)

Figure 35> Switch configuration parameters

Item	Description
Function	The function of this switch can be any of the following: RTE#1 - RTE for door 1 RTE#2 - RTE for door 2 Tamper #1 ~ #3 - Tamper input Clear alarm #1 ~ #3 - Clears alarm output Disable Switch – The switch is disabled. That is, no function is assigned to the switch.
Delay	Delay before the switch input is acknowledged by BEACon in range from 0 to 60000 milliseconds (0~60sec). It is mainly used to debounce switch inputs or to wait for the door to be mechanically stabilized in closed position before the door strike locks again.
Switch type	The polarity of the switch. Choose polarity from Normally Open (N.O.) or Normally Closed (N.C.)

3.5.4. Lock-up password

You may want to setup a password for BEACon menu system for security reasons. To change the password, you must enter the current password, as shown in the Figure 37.

Also, you can unlock this BEACon menu system by changing the none of password.

New password

Confir m password *****

Figure 36> Setting a new lock-up password

Enter password *****

Figure 37> Entering current password

3.5.5. Adjust time

This menu adjusts date and time of the attached readers.

The date format is “YYMMDD” as seen in the Figure 38. In this example, setting the date to “1 Dec, 2005” is illustrated.

Set Date(YYMMDD) 051201

Figure 38> Setting current date

The time format is “hhmmss” as seen in the Figure 39. In this example, setting the time to 5:15 pm is illustrated.

Set Ti me(hhmmss) 171500

Figure 39> Setting current time

3.5.6. IP Setting

This menu is used to set up the IP address, netmask and gateway address of BEACon . Following example shows the process to set up the IP address to 192.168.1.1, the netmask to 255.255.255.0 and the gateway address to 192.168.1.1. **ENT** is replacement of “.”.

Input IP 192. 168. 1. 111

Press **ENT**

Figure 40> Setting IP address

```
Input Mask
255. 255. 255. 0
```

Press **ENT**

Figure 41> Setting Netmask

```
Input GW
192. 168. 1. 1
```

Press **ENT**

Figure 42> Setting gateway address

```
Save?
(ENT: Y/ESC: N)
```

If press **ENT**, IP will be changed

```
IP Setting
Success
```

If press **ESC**, IP will be unchanged

```
IP Setting
Cancel ed
```

Figure 43> Setting IP address

3.5.7. ID Setting

This menu is setting the ID of BEACon. This ID is unique and is required for networking with BioAdmin. If the ID of a packet from BioAdmin is same with this ID, BEACon will be response. But if not, the protocol packet is ignored.

```
Enter BEACon ID
1
```

Save?
(ENT: Y/ESC: N)

If press **ENT**, the ID will be changed.

BEACon I D
Success

If press **ESC**, the ID will be unchanged.

BAECon I D
Cancel ed

Figure 44> Setting BEACon ID

3.5.8. Baudrate Setting

This menu is used to set up the baudrate of RS232/485 ports of BEACon. If the baudrate of Reader is changed, the baudrate of BEACon will be changed to same baudrate of Reader, too. 115200 is default value.

Baudrate
115200

If press **ENT**,

Save?
(ENT: Y/ESC: N)

If press **ENT**, baudrate will be changed.

Success
Baudrate

If press **ESC**, baudrate will be unchanged.

Cancl ed
Baudrate

Figure 45> Setting Baudrate

3.6. Attach Reader

The BEACon and the readers must be configured for each other in

order to establish a secure communication channel. BEACon can communicate with readers only after this attachment process. This attachment is required once for new installations, or when the reader is changed.

You should select which reader to attach into the system.

After selecting the reader port as in the Figure 13, choose the operation mode of the reader as in the Figure 46.

Select Op. Mode
1. 1: 1
2. 1: N
3. Both

Figure 46> Choosing the operation mode

Then the BEACon will try to detect a reader connected to that port, as in the Figure 47.

Reader #2:
Detecting...

Figure 47> Trying to detect the reader connected to port 2

If the reader is found, the BEACon will setup the reader's operation mode as well as exchange security keys, and attach into the system as in the Figure 48.

Reader Attached
ID: 234

Figure 48> A reader is found with ID 234

If the attachment was not successful, an error message will show up as the Figure 49. In this case, please recheck the connection and try again.

Attach Failed

Figure 49> Failed to detect or attach a reader
