

**FM-TC**

**Datasheet**

Ver. 1.0.1

## Revision History

Rev No.	Issued date	<b>Description</b>
1.0	Jun. 10, 2005	Initial Release
1.0.1	Jul. 21, 2005	The pin outs of J4 are corrected.

---

## Contents

Overview .....	4
1. FM- Series .....	5
Table 1 UniFinger FM Series combinations .....	5
2. Features .....	5
3. Fingerprint Authentication Specifications.....	6
3.1. Fingerprint Authentication Performance .....	6
3.2. Fingerprint Sensor Specifications.....	6
3.3. Data storage .....	6
4. Hardware Specifications .....	6
4.1. Operating range.....	6
4.2. Absolute Maximum Ratings.....	6
4.3. Electrical DC characteristics( $V_{DD} = 5.0V_{dc}$ , $T_{OP} = 25^{\circ}C$ ) .....	7
4.4. Interface .....	7
4.5. Connector Specifications .....	7
4.5.1. LED port(J1) pin assignment .....	8
4.5.2. Digital I/O port (J2) pin assignment .....	8
4.5.3. Wiegand I/O port (J3) pin assignment .....	8
4.5.4. Aux interface port (J4) pin assignment .....	9
4.5.5. Host interface port (J5) pin assignment .....	9
4.5.6. Battery connector (J6) pin assignment .....	9
4.6. Physical Dimensions .....	9
Figure 1 Main board dimensions.....	10
Figure 2 Sensor dimensions.....	11
5. Communication Protocol Summary .....	12
5.1. Packet Structure .....	12
5.2. Command Summary.....	12

## Overview

The FM modules are stand-alone fingerprint systems ideal for embedded system applications where biometric security is needed. The modules are designed for manufacturers searching for an inexpensive, reliable and easy-to-integrate biometric system. The modules provide complete fingerprint solutions by incorporating fingerprint sensor interface and embedded fingerprint recognition algorithm into a half business card sized module.

The FM-series is the latest module equipped with world's leading fingerprint authentication algorithm (ranked No. 1 in FVC2004) and powerful DSP technology. Also, it supports wide range of fingerprint sensor interoperability giving you a freedom to select suitable sensor that most fits to your application. Furthermore, the fingerprint data for enrollment and verification are compatible among different sensors, even if they are based on different technologies. This feature of unification presents application manufacturers and system integrators with much more flexibility than ever before.

In addition to these features, the miniature sized module has a state-of-the-art low power design making it a perfect match in a wide range of applications from battery operated mobile equipments to network based security systems. The stands ready to meet your requirements and adapt to your applications.

## 1. FM Series

The FM-series is the latest UniFinger module equipped with world's leading fingerprint authentication algorithm, which ranked No. 1 in FVC2004. The FM-series is based on powerful DSP technology, optimized for performance while minimizing power consumptions.

Table 1 summarizes available combinations of modules and sensors.

**Table 1 UniFinger SFM3500 Series combinations**

Model name	Supported sensors	Main board
FM-FL	Authentec AF-S2	FM
SFM3500-PR	BMF BLP-100	
FM-FC	Atmel Fingerchip	FM
FM-OP	Optical sensor I	FM
FM-TC	UPEK TouchChip TCS1CD	FM
FM-TC2	UPEK TouchChip TCS2CF	

## 2. Features

- **World best authentication performance (ranked No. 1 in FVC2004)**
- High speed fingerprint verification
- Compact size
- Low power consumption
- Fast power on time
- Supports various communication interfaces
- Supports fingerprint data encryption
- Supports various fingerprint sensors
- Highly configurable I/O signals
- Operates with a single 5.0v dc supply

## 3. Fingerprint Authentication Specifications

### 3.1. Fingerprint Authentication Performance

EER*	<0.1%
Enrollment time	<1 sec
Verification time	<1 sec

\*EER is dependent on databases

### 3.2. Fingerprint Sensor Specifications

Manufacturer	UPEK
Device Name	TouchChip TCS1CD
Sensor technology	Capacitive
Sensing area	12.8mm x 18.0mm
Image size(pixels)	256x360
Image resolution	508 dpi

### 3.3. Data storage

Template capacity	9,000 at 4M Flash ( 19,000 at 8M )
LOG capacity	12,800 event
User memory	256 Bytes

## 4. Hardware Specifications

### 4.1. Operating range

Parameter	Symbol	Min	Typ	Max	Units
Supply voltage	$V_{DD}$	4.5	5.0	5.5	V
Operating temperature	$T_{OP}$	0		70	°C

### 4.2. Absolute Maximum Ratings

Parameter	Symbol	Min.	Max.	Units
Power supply voltage	$V_{DD}$	-0.3	6	V
Input voltage on signal pins	$V_{IN}$	-0.3	6	V

#### 4.3. Electrical DC characteristics ( $V_{DD} = 5.0V_{dc}$ , $T_{OP} = 25^{\circ}C$ )

Parameter	Symbol	Min.	Typ.	Max.	Units
Supply current (idle)	$I_{DD1}$		110		mA
Supply current (scanning)	$I_{DD2}$		115		mA
Supply current (identifying)	$I_{DD3}$		140	150	mA
High level input voltage	$V_{IH}$	2.0		5.5	V
Low level input voltage	$V_{IL}$	-0.3		0.6	V

#### 4.4. Interface

Type	Description
Host communication	RS-232C or RS422/485 level Baud rates up to 115.2kbps (factory default: 115.2kbps)
Aux communication	RS-232C or CMOS level Baud rates up to 115.2kbps (factory default: 115.2kbps)
Digital I/O	CMOS(0~5V) level 3 CMOS input, 3 CMOS output pins
LED driver	3 LED drivers. Common anode. Active low outputs.
Wiegand	CMOS(0~5V) level Input and output ports supported

#### 4.5. Connector Specifications

Connector	Usage
J1	LED output port
J2	Digital I/O port. CMOS(0~5V), 3 Inputs, 2 Outputs
J3	Wiegand I/O port.
J4	Aux interface port
J5	Host interface port
J6	Battery connector for time keeping
J8	Sensor interface port

1. Connectors J1 ~ J6 are Molex 53261-8090 compatible board-to-wire

connectors.

2. Power can be supplied by one of J2, J3, J4 or J5 connectors.

#### 4.5.1. LED port(J1) pin assignment

Name	pin #	Type	Functions
GND	1	Power	Power Ground
LED0	2	Output	Active low, Current sink up to 20mA Current limit resistors integrated (220 Ohm)
LED1	3	Output	
LED2	4	Output	
VCC	5	Power	Power Supply for LEDs. 5Vdc

#### 4.5.2. Digital I/O port (J2) pin assignment

Name	pin #	Type	Functions
GND	1	Power	Power Ground
IN0	2	Input	CMOS(0~5V), Active high input Internally pulled down with 47kOhm resistors
IN1	3	Input	
IN2	4	Input	
VCC	5	Power	Power Supply. 5Vdc
OUT0	6	Output	CMOS(0~5V), Active high output
OUT1	7	Output	
OUT2	8	Output	
GND	9	Power	Power Ground

#### 4.5.3. Wiegand I/O port (J3) pin assignment

Name	pin #	Type	Functions
GND	1	Power	Power Ground
WIN0	2	TTL input	Wiegand input, DATA0
WIN1	3	TTL input	Wiegand input, DATA1
NC	4	No connect	Reserved for future use
VCC	5	Power	Power Supply. 5Vdc
WOUT0	6	TTL output	Wiegand output, DATA0
WOUT1	7	TTL output	Wiegand output, DATA1
NC	8	No connect	Reserved for future use
GND	9	Power	Power Ground

## 4.5.4. Aux interface port (J4) pin assignment

Name	pin #	Type	Functions
GND	1	Power	Power Ground
TX3	2	RS232C	Aux port transmit data
RX3	3	RS232C	Aux port receive data
VCC	4	Power	Power Supply. 5Vdc
TX4C	5	CMOS	Aux port transmit data
RX4C	6	CMOS	Aux port receive data
GND	7	Power	Power Ground

## 4.5.5. Host interface port (J5) pin assignment

Name	pin #	Type	Functions
GND	1	Power	Power Ground
TX1	2	RS232C	Host port transmit data
RX1	3	RS232C	Host port receive data
TX2P	4	RS422/485	Host port non inverting transmit data
VCC	5	Power	Power Supply. 5Vdc
RX2P	6	RS422/485	Host port non inverting receive data
TX2N	7	RS422/485	Host port inverting transmit data
RX2N	8	RS422/485	Host port inverting receive data
GND	9	Power	Power Ground

## 4.5.6. Battery connector (J6) pin assignment

Name	pin #	Type	Functions
GND	1	Power	Power Ground
VBATT	2	Power	RTC power supply. 3~3.6V
GND	3	Power	Power Ground

## 4.6. Physical Dimensions

Parameter	Values
Main board	63mm x 43mm x 10mm (LxWxH)
Sensor	20.4mm x 27mm x 3.5mm (WxLxH)

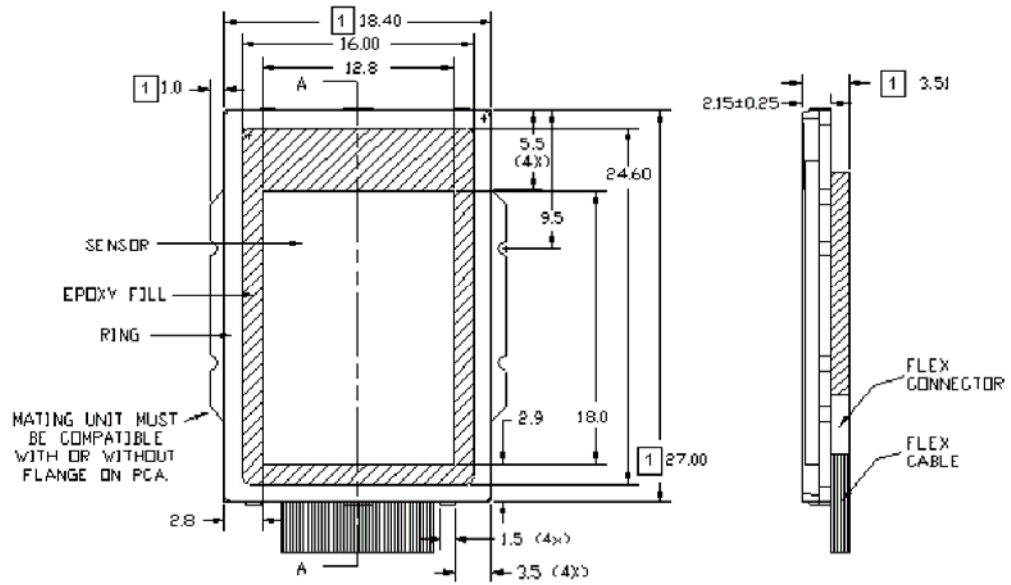

**Figure 2**      **Sensor dimensions**

*Dimensions in millimeters. Image from UPEK*

## 5. Communication Protocol Summary

The FM modul provides a proprietary communication protocol for easy interface with most host systems. The protocol based on fixed sized packets. Only fingerprint image, template data, and user lists are transmitted as appended to the packet. Checksum functionality is supported to ensure consistency of transmitted data.

Please refer to *UniFinger Protocol Manual* for detailed information.

### 5.1. Packet Structure

Start code	Command	Param	Size	Flag	Checksum	End code
1byte	1byte	4bytes	4bytes	1byte	1byte	1byte

### 5.2. Command Summary

Command	Code	Description
SW	0x01	Write system parameter
SF	0x02	Save system parameter
SR	0x03	Read system parameter
CS	0x1A	Calibrate sensor
SS	0x04	Check system status
CA	0x60	Cancel
ES	0x05	Enroll by scan
ESA	0x70	ES with administrator verification
EI	0x06	Enroll by image
EIX	0x80	EI through data transfer protocol
ET	0x07	Enroll by template
EW	0x1C	Enroll by Wiegand ID
EWA	0x71	EW with administrator verification
VS	0x08	Verify by scan
VI	0x09	Verify by image
VIX	0x82	VI through data transfer protocol
VT	0x10	Verify by template
VW	0x1D	Verify by Wiegand ID

VH	0x22	Verify host template by scan
IS	0x11	Identify by scan
II	0x12	Identify by image
IIX	0x81	II through data transfer protocol
IT	0x13	Identify by template
DA	0x17	Delete all templates
DAA	0x74	DA with administrator verification
DT	0x16	Delete template
DS	0x1E	Delete by scan
DSA	0x72	DS with administrator verification
DW	0x1F	Delete by Wiegand ID
DWA	0x73	DW with administrator verification
LT	0x18	List user ID
CT	0x19	Check user ID
FP	0x23	Fix all provisional templates
DP	0x24	Delete all provisional templates
RI	0x20	Read image
RIX	0x84	RI through data transfer protocol
SI	0x15	Scan image
SIX	0x83	SI through data transfer protocol
RT	0x14	Read template
ST	0x21	Scan template
KS	0x35	Scan template with challenge data
KW	0x34	Write encryption key
ML	0x31	Get size of user memory
MW	0x32	Write to user memory
MR	0x33	Read from user memory
TW	0x3A	Write current time
TR	0x3B	Read current time
LN	0x3C	Get number of log data
LR	0x3D	Read log data
LD	0x3E	Delete log data
WW	0x41	Write Wiegand configuration

---

WR	0x42	Read Wiegand configuration
WG	0x43	Get Wiegand input
WS	0x44	Set Wiegand output
WM	0x68	Map Wiegand id to input function
WL	0x69	List Wiegand id mapping
WC	0x6A	Clear Wiegand id mapping
IW	0x47	Write input configuration
IR	0x48	Read input configuration
IG	0x49	Get input state
OW	0x4A	Write output configuration
OR	0x4B	Read output configuration
OL	0x4C	Read output configuration list
OS	0x4D	Set output state
GW	0x37	Write GPIO configuration
GR	0x36	Read GPIO configuration
GC	0x38	Clear GPIO configuration
GD	0x39	Set default GPIO configuration
AW	0x65	Write administration level
AR	0x66	Read administration level
AC	0x67	Clear administration level

